

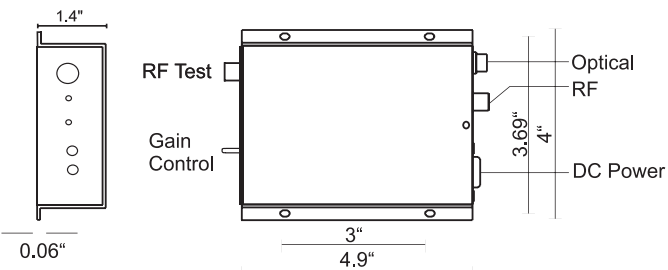

## Our Company

Foxcom, established in 1993, is an international team of satellite professionals dedicated to delivering innovative high performance satcom products worldwide. Our global sales and marketing efforts are divided between our Princeton, NJ sales office supporting our customers in North and South American while our research and manufacturing center, Israel, supports sales into Europe, APAC, and Africa. Foxcom, which is ISO 9001:2000 accredited, performs all R&D, final assembly, and testing in its Israeli office, delivering products which meet CE (European Union) and FCC approvals.

**Foxcom: Dedication to Satellite Communications.**

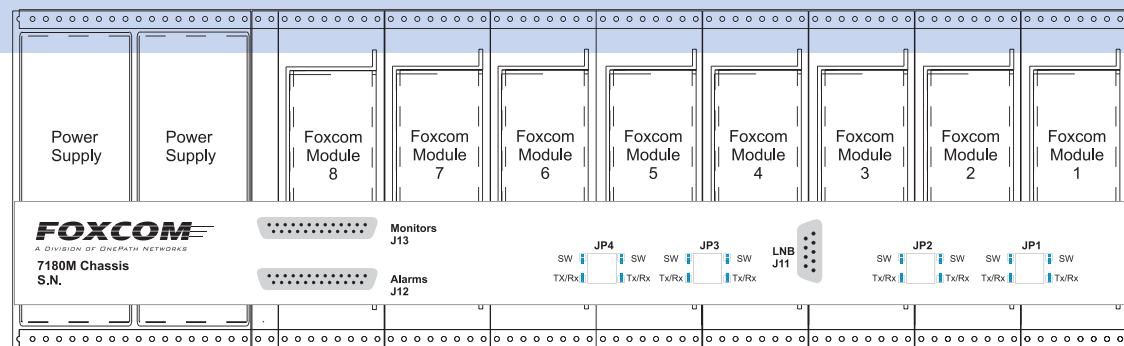

Physical Characteristics	
Chassis Capacity	8 plug-ins
Chassis Size	19" x 5.25" x 7"
Unit Size	5" x 4.8" x 1.6"
RF Connector	F-type standard
Power for Chassis	100 to 240 VAC 50/60 90 watts (max)
Transmitter	15 VDC or 18 VDC @ 400 mA (max)
Receiver	15 VDC or 18 VDC @ 300 mA (max)
Operating Temp. Range	-10 to +55° C
Storage Temp. Range	- 40 to +85° C

Accessories	
Model	Description
2040	1:1 Redundancy
2100	Pre/Post RF Amplifier
2380	Relay Adapter
7050	Serial Transceiver 1-5 Channels
7180M	8 Slot Chassis / Power Supply
7001P	7180M Standby Power Supply

Options	
Model	Description
-L	Internal LNB Biasing from TX Input
-50	50 Ohm BNC Option
-75	75 Ohm BNC Option
-30	Extended Frequency Response to 3000 MHz
-SMA	SMA connector

All specs are subject to change without prior notice. Foxcom 2009. Doc. No. 130302B7



- *Broadband Transmission – 950-2150 MHz (3000 MHz available)*
- *Protocol Transparent – transmits all video, audio and data modulation formats*
- *Transmission distances ranging from 100m to 60km*
- *Gain Control, Indicators, Alarms and Monitors*
- *Single or Multi Channel up or downlink transmission*
- *Interface with M & C Systems for remote signal monitoring*

## L-Band Fiberoptic Interfacility Links

Foxcom's Sat-Light L-Band interfacility links (IFLs) offer a high performance, cost effective alternative to conventional coaxial-cabled systems. Sat-Light's L-band IFLs cover the range of 950 - 2150 MHz (with optional coverage to 3000 MHz). They are used for the transmission over single mode fiber optic cable of block downconverted C, extended C, X or Ku band signals. Transmission of L-band Inmarsat signals as well as communication radar transmission and reception are also made possible using Foxcom's L-Band range of products.

Sat-Light IFLs consist of an optical transmitter, which receives the RF signal from the LNB, and an optical receiver that connects to a satellite receiver. All satellite modulation schemes are accommodated; digital or analog. Format independence is achieved by inherently low phase noise. The RF signal, an entire L-Band polarization, is converted at the transmitter to an optical signal by direct modulation of a semiconductor laser diode. At the receive end, the optical signal is converted back to an RF signal by a photodiode.

The Sat-Light IFLs function as a transparent link between the satellite antenna and the Network Operations Center (NOC) or control room. System limitations in using coaxial cable are overcome by the simplicity and performance of fiberoptic connections to provide the highest levels in signal quality

<p><b>Corporate Office Israel</b> Beck Science Center 8 Hartom Street Har Hotzvim P.O.Box 45092 Jerusalem 91450 Tel: +972.2.589.9888 Fax: +972.2.589.9898 <a href="http://www.foxcom.com">www.foxcom.com</a></p>	<p><b>US Office</b> Princeton Forrestal Village 136 Main St., Suite 300 Princeton, NJ 08540 Tel: +1.609.514.1800 Fax: +1.609.514.1881</p>	<p><b>South Africa Office</b> Block 4, Kingfisher Office Park 2 28 Siphosethu Rd. Mt. Edgecombe Durban, KwaZulu Natal Tel: +278.7.751.3911 Fax: +278.6.501.6624 <a href="mailto:sales@foxcom.com">sales@foxcom.com</a></p>
--	---	--



## L-Band Fiberoptic Interfacility Links

**Foxcom** offers a wide range of products to meet all your specific satcom needs. Short distance downlink applications can be achieved using our cost effective isolated Fabry-Perot products while professional and more demanding long distance or multi-carrier applications can be met using our high dynamic range DFB lasers – delivering excellent signal quality even under varying conditions.

Product options include Automatic and Manual Gain Control. Automatic Gain Control (AGC) at the transmitter site sets and maintains optimum operation over a wide range of input signal levels. At the receiver site AGC maintains the RF level regardless of optical power or distance from transmission site. Alternatively, Manual Gain Control (MGC) at the transmitter site allows the system operator to maintain optimum operation over a wide range of input signal levels on the transmitter site and RF output level on the receiver site.

Front panel RF test ports, LEDs, back panel monitors and alarms allow for complete status system monitoring and for interfacing with M&C systems. All transmitter units can provide 14VDC/350mA for optional LNB powering.

The Sat-Light system consists of compact modules that plug into a 19" wide 3U chassis/power supply. The chassis allows accommodation of up to 8 Sat-Light modules in addition to main and standby power supplies. Standalone versions are also available.

Accessories are available for the Sat-Light IFLs to accommodate the wide variety of system design preferences in use.

### Typical L-Band Application with 1:1 Redundancy

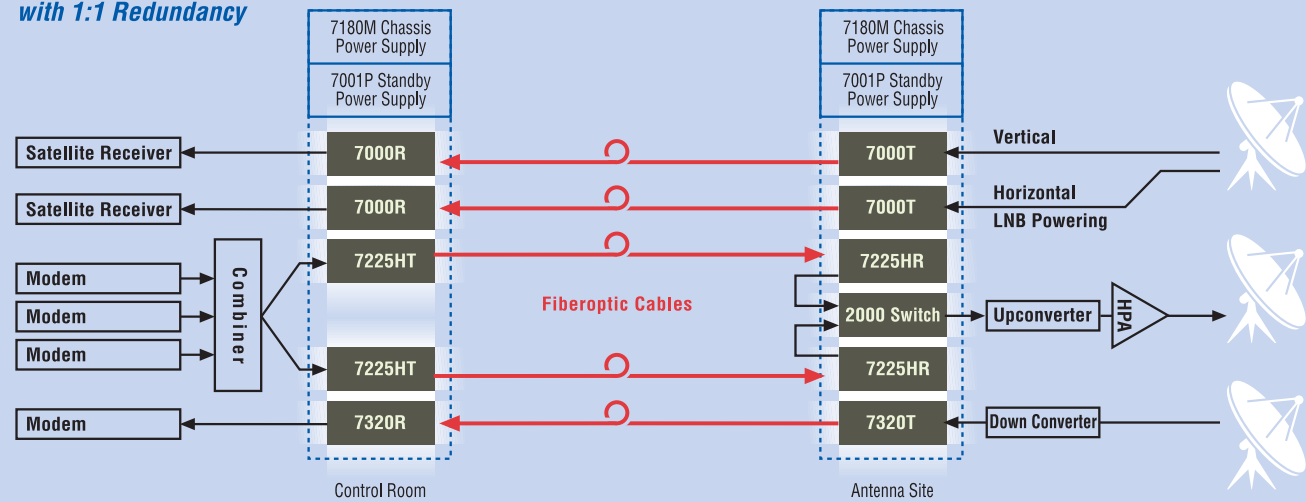

### L-Band Interfacility Links

Model	Application	Frequency	Optical Budget	Gain Control	Laser
7320	Short Distance Up/Downlink	950-2150 MHz	3 dB / 2 km	Manual	Isolated Fabry-Perot
7000	Intermediate Distance Up/Downlink	950-2150 MHz	8 dB / 12 km	Automatic/Manual	Isolated Fabry-Perot
7225	Long Distance Multi-Carrier Up/Downlink	950-2150 MHz	16 dB / 40 km	Manual	DFB
7225H / 7226H	High Power Multi-Carrier Up/Downlink	950-2150 MHz	3 dB / 2 km	Manual	DFB
7410F	Short Distance Up/Downlink	950-2150 MHz	3 dB / 2 km	Manual (Rx Only)	Isolated Fabry-Perot
7490	Ultra Long Distance Up/Downlink	950-2150 MHz	28 dB	Manual	DFB

### 7320/7410F

The 7320 and 7410F Systems transmit and receive an entire L-Band polarization over singlemode fiber from a satellite antenna to reception equipment up to 2 kilometers away while preserving signal quality. The 7320 comes with MGC on both the Tx and Rx, providing maximum link stability. The 7410F has Automatic Gain Control on the Tx, and MGC on the Rx.

### 7000

The 7000 Advanced Interfacility Link transmits and receives an entire L-Band RF signal over single-mode fiber from a satellite antenna LNB to a control room up to 15 kilometers away guaranteeing superior signal quality. This feature rich link includes auto or manual gain control and front panel RF test ports.

### 7225

The 7225 Long Distance Multi-Channel system is a high dynamic range fiber optic link. The 7225 transmits and receives an entire L-Band polarization up to 40 kilometers, providing excellent signal quality under varying conditions encountered in multi-channel environments. For ultra-long distance applications the 7225 can be ordered with a 1550 nm laser, the 7225-15.

### 7225H/7226H 7490

The 7225H is a multi-carrier link designed for high input power levels. Featuring a high dynamic range laser the link is ideal for both up and down link applications. The 7225H provides the same enhanced performance as the 7225, but allows higher input levels which match the power output of today's L band modems. For front panel test port support, select, 7226H

The Sat-Light 7490 is a high performance L-Band link (950- 2200) offering superior performance with a high optical budget: 28 dB in up or downlink applications. The 7490's high optical budget was designed for ultra-long distance applications (over 90 Km) or those requiring Course Wave Division Multiplexing (CWDM). MGC in the transmitter and receiver assure optimal link set-up.

### RF Characteristics

	7320/7410F	7000	7225	7225H / 7226H	7490
<b>Frequency Range</b>	950-2150 MHz	950-2150 MHz <sup>5</sup>	950-2150 MHz <sup>5</sup>	950-2150 MHz <sup>5</sup>	950-2150 MHz
<b>Flatness</b>	± 1.5 dB max ± 0.25 dB @ any 36 MHz	± 1.25 dB max ± 1 dB typical ± 0.25 dB @ any 36 MHz	± 1.25 dB max ± 1 dB typical ± 0.2 dB @ any 36 MHz	± 1.25 dB max ± 1 dB typical ± 0.2 dB @ any 36 MHz	± 1.5 dB max ± 0.25 dB @ any 36 MHz
<b>VSWR 75</b>	1:1.6	1:1.6	1:1.6	1:1.6	1:1.6
<b>IMD Products</b>	-40 dBc	-40 dBc	-50 dBc	-40 dBc	-40 dBc
<b>CNR (min)<sup>1</sup></b>	45 dB @ 36 MHz / 2 km	40 dB @ 36 MHz / 10 km	40 dB @ 36 MHz / 10 km	60 dB @ 36 MHz / 2 km	35 dB @ 36 MHz <sup>4</sup>
<b>Input Signal (max)</b>	-20 dBm	-20 dBm	-20 dBm	-5 dBm	-20 dBm
<b>Output Signal (max)</b>	-20 dBm	-20 dBm	-20 dBm	-5 dBm	-20 dBm
<b>Maximum Input Power (without damage)</b>	+10 dBm	+10 dBm	+10 dBm	+10 dBm	+10 dBm
<b>Gain Stability</b>	0.25 @ 24 hrs	0.25 @ 24 hrs	0.25 @ 24 hrs	0.25 @ 24 hrs	0.25 @ 24 hrs
<b>Link Gain</b>	20 dB	20 dB	20 dB	20 dB	+/- 10 dB (Rx only)
<b>OIP3 (dBm)</b>	0	0 dBm	+5 dBm	+ 15 dBm	-5 dBm
<b>Noise Figure (typical)</b>	22 dB <sup>2</sup>	20 dB <sup>2</sup>	15 dB <sup>2</sup>	25 dB <sup>2</sup>	38 dB <sup>3</sup>
<b>SFDR<sup>1</sup></b>	99 dB Hz 2/3 @ -25 dBm (typ)	100 dB Hz 2/3 @ -25 dBm (typ)	102 dB Hz 2/3 @ -25 dBm (typ)	109 dB Hz 2/3 @ -25 dBm (typ)	102 dB Hz 2/3 @ -25 dBm (typ)

<sup>1</sup>@ Maximum Input @ 1 dB Optical Loss @ Unity Gain <sup>2</sup>Input power of -40 dBm @ 5 dB Optical Loss <sup>3</sup>16 dB optical loss  
<sup>4</sup>@maximum input @ 16 dB optical loss <sup>5</sup> 950 - 3000 MHz option available

### Optical Characteristics

	7320/7410F	7000	7225	7225H / 7226H	7490
<b>Optical Wavelength</b>	1310 nm ± 10 nm	1310 nm ± 10 nm	1310 nm ± 10 nm	1310 nm ± 10 nm	1550 nm ± 10 nm /CWDM
<b>Optical Power Output</b>	-3 dBm (min.)	-3 dBm (min.)	+3 dBm (min.)	+3 dBm (min.)	+5 dBm / +3 dBm CWDM
<b>Optical Connector</b>	FC/APC	FC/APC	FC/APC	FC/APC	FC/APC
<b>Optical Budget</b>	3 dB / 2 km*	8 dB / 20 km*	16 dB / 40 km*	3 dB / 2 km*	28 dB

\*1310 0.4 dB/km Fiber Only 1550 0.25 dB/km Fiber Only