



Ku-Band Fiber Optic IFL

Ku-Band

- Downlink (10.7 to 12.75 GHz)
- Advanced technology employing Electro-Absorption Modulation monolithic laser
- High Performance: Low Noise Figure, & Minimal Distortion
- Exceeds INTELSAT IESS-308/309 and EUTELSAT EESS-501 phase noise specifications
- Internal Filter rejects spurious out of band interference by > 70 dB
- Feature Rich - Gain Controls, RF Test port, Alarms, and Monitors



Foxcom's Sat-Light Ku-Band fiberoptic interfacility links transmit and receive downlink signals in the 10.7 to 12.75 GHz range between antennas and control rooms or NOCs. Foxcom's IFLs offer a high performance alternative to conventional coaxial-cabled systems, reducing the need for waveguide and minimizing signal attenuation.

The Sat-Light IFLs function as a transparent link, transmitting all satellite modulation formats carrying an entire polarization on each link. System limitations in using coaxial cable are overcome by the simplicity and performance of fiberoptic connections to provide the highest levels in signal quality. Foxcom achieves this by using state of the art lasers to provide these high efficiency, low noise analog links.

A typical Ku-Band link consists of an optical transmitter which receives the RF signal, transmitting it over singlemode fiber to an optical receiver which reconverts the optical signal to RF.

Foxcom's advanced fiberoptic technology reduces the attenuation, slope, phase shift, and group delay maintaining extremely low levels over distances of up to 15 kilometers. The Ku-Band's link cost effective high performance lasers produce negligible chirp and optical distortion; critical for long distance links. The EAM monolithic design, versus connectorized component electro-optics, assures high performance along with excellent reliability. The links are provided with test ports, status and fault LEDs, and gain controls.

FOXCOM

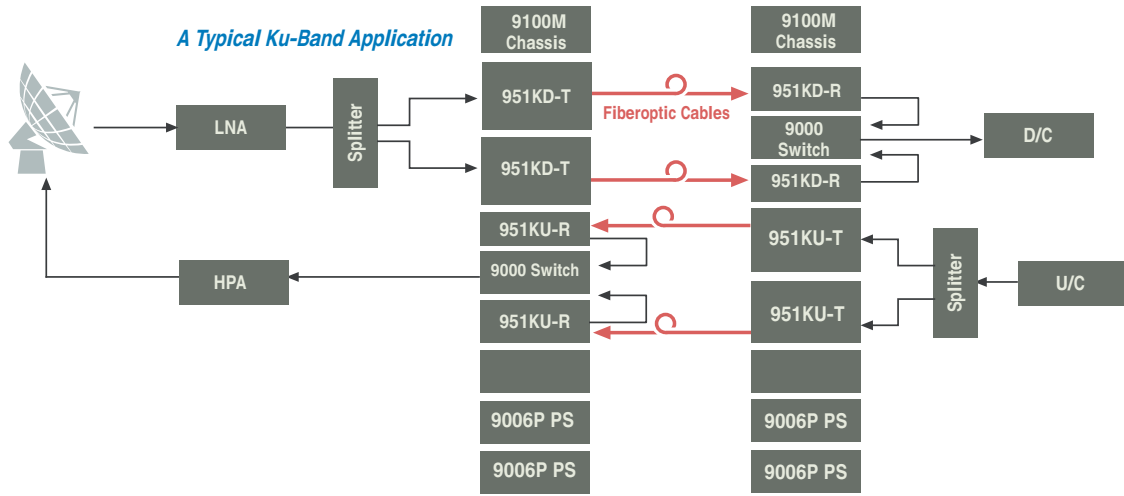

Optical Specifications

Optical Wavelength	1550 nm
Optical Power Output	-1 dBm (typical)
Optical Connector	FC/APC
Optical Budget	3 dB (15 km)
Optical Return Loss	-60 dB all connectors

Physical Specifications

Chassis Size & Capacity	8 receivers or 4 transmitters max.
Chassis	19" 3U standard format
Unit Size	Receiver 5" x 5" x 1.5" Transmitter 5" x 5" x 3"
RF Connector	SMA
Power for Transmitter	9W (max.)
Power for Receiver	5.5W (max.)
Operating Temp. Range	-10 to 55°C
Storage Temp. Range	-30 to 75°C

Options

Fixed Gain	Add - FG
------------	----------

Chassis/Power Supply Specifications

Parameter	Specification
Frequency Range	10700 - 12750 MHz
Out of Band Rejection	>70 dB
Flatness	± 0.2 dB / 48 MHz ± 0.7 / 500 MHz (typ.) ± 1.0 / Full band (typ.)
Intermodulation	-50 dBc (max.), -55 dBc (typ.)
CNR (36 MHz BW)	>50 dBc
Input Signal	
Low Gain Setting	-25 to -10 dBm
High Gain Setting	-40 to -25 dBm
Output Signal	
Low Gain Setting	-40 to -25 dBm
High Gain Setting	-25 to -10 dBm
Gain Stability @ Constant Temp	± 0.15 dB / 24 hours
OIP3 (from min to max gain)	
Low Gain Setting	-15 to 0 dBm (typ.)
High Gain Setting	0 to +15 dBm (typ.)
Noise Figure @ max input gain	
Low Gain Setting	<22 dB (typ.)
High Gain Setting	<9 dB (typ.)
Group Delay Variation: Peak to peak	0.4 ns (typ.)
SFDR	>100 (typ.)
Input/Output Impedance	50 Ohm
Input/Output VSWR	1.4:1
Maximum RF Input (with no damage)	
High Gain Setting	-10 dBm
Low Gain Setting	+5 dBm
Gain Control	Manual front panel – standard (Fixed gain optional)
Test Port Coupling	20 dB ± 1.0

* two carriers at max input and output power

All specifications subject to change without notice.
All specifications are typical unless stated otherwise

Ordering Information

Ku Band D/L TX	951KD-T
Ku Band D/L RX	951KD-R

FOXCOM
Complete RF-2-Fiber Solutions

Foxcom Inc.
Princeton Forrestal Village
136 Main Street
Suite 300
Princeton, NJ 08540
Tel: 609-514-1800
Fax: 609-514-1881

Foxcom Ltd.
Beck Science Center
8 Hartom Street, Har-Hotzvim
P.O. Box 45092, Jerusalem 91450
Israel
Tel: +972-2-589-9888
Fax: +972-2-589-9898

E-mail: sales@foxcom.com

Website: www.foxcom.com