

- Uplink (5.8 to 6.8 GHz) and Downlink (3.4 to 4.2 GHz)
- High Performance: Low Noise Figure, & Minimal Distortion
- Exceeds INTELSAT IESS-308/309 and EUTELSAT EESS-501 phase noise specifications
- Feature Rich – Gain Controls, RF Test port, Alarms, and Monitors
- Compact 3U Chassis and Redundant Power Supplies



Foxcom's Sat-Light C-Band fiberoptic interfacility links transmit and receive uplink and downlink signals in the 3.4 to 6.8 GHz range between antennas and control rooms or NOCs. Foxcom's IFLs offer a high performance alternative to conventional coaxial-cabled systems, reducing the need for waveguide and minimizing signal attenuation.

The Sat-Light IFLs function as a transparent link, transmitting all satellite modulation formats carrying an entire polarization on each link. System limitations in using coaxial cable are overcome by the simplicity and performance of fiberoptic connections to provide the highest levels in signal quality. Foxcom achieves this by using state of the art lasers to provide these high efficiency, low noise analog links.

A typical C-Band link consists of an optical transmitter, which receives the RF signal, transmitting it over singlemode fiber to an optical receiver which reconverts the optical signal to RF.

Foxcom's advanced fiberoptic technology reduces the attenuation, slope, phase shift, and group delay, maintaining extremely low levels over distances of up to 15 kilometers. The C-Band's link state of the art lasers produce negligible chirp and optical distortion; critical for long distance links. The links are provided with test ports, status and fault LEDs, and gain controls.

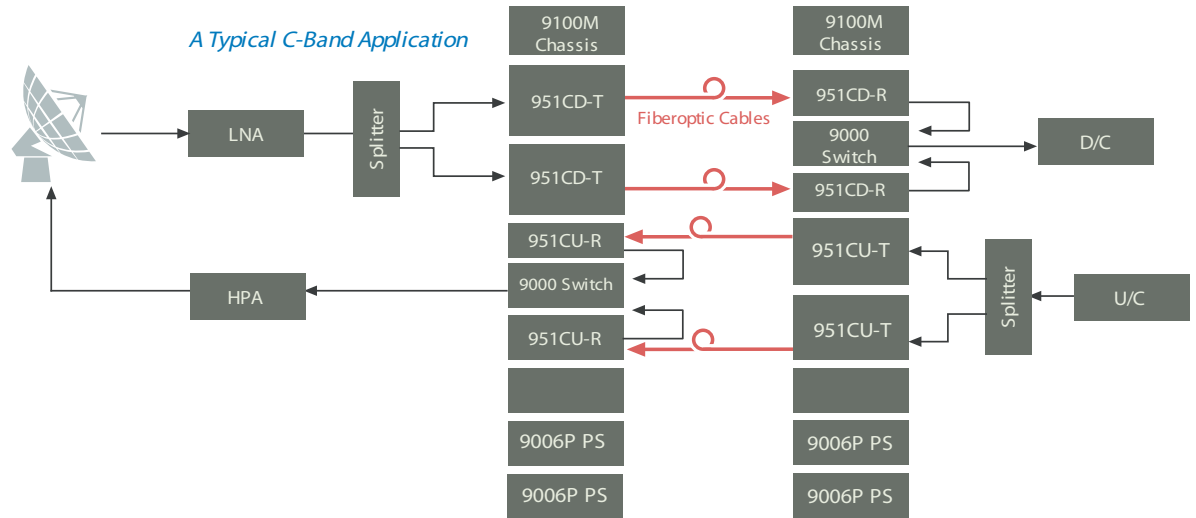

Optical Specifications

Optical Wavelength	1550 nm (DWDM optional)
Optical Power Output	-3 dBm (typical)
Optical Connector	FC/APC
Optical Budget	4 dB (15 km)
Optical Return Loss	-60 dB all connectors

Physical Specifications

Chassis Size & Capacity	8 receivers or 4 transmitters max.
Chassis	19" 3U standard format
Unit Size	Receiver 5" x 5" x 1.5" Transmitter 5" x 5" x 3"
RF Connector	SMA
Power for Transmitter	8 W
Power for Receiver	2.6 W
Operating Temp. Range	-10 to 55° C
Storage Temp. Range	-30 to 75° C

Options

Fixed Gain	Add - FG
Automatic Gain Control	Add - AGC

RF Specifications

	C Band Downlink TX Model 951CD-T RX Model 951CD-R	C-Band Uplink TX Model 951CU-T RX Model 951CU-R
Parameter	Typical Downlink Specs	Typical Uplink Specs
Frequency Range	3400 - 4200 MHz	5800 - 6725 MHz
Flatness	± 0.25 dB / 48 MHz ± 0.75 / 500 MHz	± 0.25 dB / 48 MHz ± 0.75 dB / 500 MHz
Input/Output VSWR	<1.5:1	< 1.5:1
Intermodulation*	> -50 dBc	> -50 dBc
CNR (48 MHz BW)	>45 dBc	>45 dBc
Input Signal Range	-5 to -25 dBm	-5 to -20 dBm
Output Signal Range	-5 to -25 dBm	-5 to -20 dBm
Gain Stability @ Constant Temp	± 0.15 dB / 24 hours	± 0.15 dB / 24 hours
Link Gain	0 dB adjustable	0 dB adjustable
OIP3 (@ max gain)	+15 dBm typical	+20 dBm typical
Noise Figure @ max input gain	<23 dB	28 dB
Group Delay Variation: Peak to peak	0.3 ns	0.4 ns
Input/Output Impedance	50 Ohm	50 Ohm
Maximum RF Input with no damage	+5 dBm for 60 seconds	+5 dBm for 60 seconds
Gain Control	Manual front panel - standard (Fixed gain or AGC optional)	Manual front panel - standard (Fixed gain or AGC optional)

*two carriers at max input and output power

Ordering Information

C Band U/L TX	951CU-T
C Band U/L RX	951CU-R
C Band D/L TX	951CD-T
C Band D/L RX	951CD-R

Preliminary Data Sheet All specifications subject to change



Complete RF-2-Fiber Solutions

Foxcom Inc.
Princeton Forrestal Village
136 Main Street
Suite 300
Princeton, NJ 08540
Tel: 609-514-1800
Fax: 609-514-1881

Foxcom Ltd.
Beck Science Center
8 Hartom Street, Har-Hotzvim
P.O. Box 45092, Jerusalem 91450
Israel
Tel: +972-2-589-9888
Fax: +972-2-589-9898

E-mail: sales@foxcom.com

Website: www.foxcom.com