

HFC MiniNode, Fiber Return and Receiver

- Single Fiber Solution for DBS/DTH/HDTV, CATV, High Speed Internet, CCTV, and VHF/UHF
- Cost Effective Solution for Advanced Two-Way MDU Service
- Up to 3.0 GHz of Bandwidth to the Home
- Integrate Existing Architecture into a Fiber Based System



Foxcom's SDTVplus HFC Fiber Return Path MiniNode and Return Path Receiver provide a fully integrated solution for two-way hybrid fiber-coax deployment in MDUs.

While providing a simple to install and use video distribution system, the MiniNode's fiberoptic return path allows for two way and advanced services, such as HDTV, cable modems, VOD, and security. The MiniNode converts the incoming optical signal to RF and then distributes the signal to each living unit. Manual Gain Control (optional) can be used to insure proper power levels.

Return path signals are transmitted from each subscriber to the MiniNode. An integrated laser converts the RF signals to optics and delivers these signals back to the headend. Specific lasers can be selected pursuant to the network requirements (e.g. Fabry-Perot, DFB, CWDM). Both forward and reverse path optical signals are transmitted over singlemode fiber.

The SDTVplus Fiber MiniNode is the ideal MDU solution, for garden style living, high rise apartments, stadiums, hotels, or office parks; anywhere a high-density solution is required.

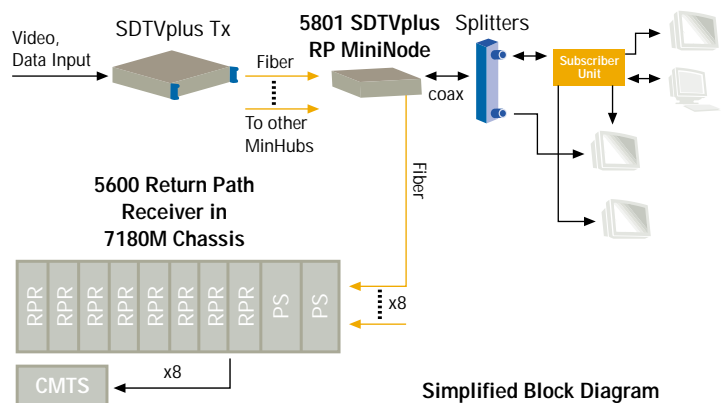

Simplified Block Diagram

Fiber Return Path MiniNode and Receiver

RP MiniNode Specifications (P/N 5801)

Forward Path Specifications				
Input Optical Power Range	-4 to +1 dBm			
CATV Output				
Frequency Range	54 - 862 MHz			
Output Power (dBu V/Ch.)	@ 54 MHz		@ 862 MHz	
60 Channels	+100		+103	
Performance using: (@ 3.6% OMI)	CNR	CSO @	CTB @	
SDTVplus 1310 nm Tx	52 dB¹	60 dB	62 dB	
SDTVplus 1550 nm Tx	53dB	66 dB	66 dB	
Uplift	+3 dB			
DBS Output				
Frequency Range	950 - 3000 MHz			
Output Power (dBm / Transponder)	@ 950 MHz		@ 2 GHz	
	-3		+1	
CNR @ 36 MHz	35 dB (min.)			
Uplift	+4 dB			
Reverse Path Specifications				
Laser	Isolated FP	FP	DFB	CWDM
Optical Output Power	1 mW	2 mW	2 mW	2, 3, 4 mW
Wavelength (nm)	1310	1550	1310	1550
	1470-1610			
Dynamic Range dB	Isolated FP 1 mW		FP 2 mW	DFB 2 mW
NPR @ 40 dB	14		10	14
NPR @ 43 dB	11		-	11
Optical Loss	@ 4 dB			@ 6 dB
RF Input Power	5 to 20 dBmV (total power)			
Frequency Range	5 to 42 MHz			
Impedance	75 Ohms			
Return Loss	13 dB (min.)			
Flatness	±1 dB			
General Specifications				
Optical Items	SC/APC (FC/APC optional), Single Mode Fiber, Fusion Splicing Only			
RF Output Connector	F/female			
Manual Gain Control (optional)	±10 dB (Forward Path)			
Power Requirements	12.5 VDC±0.5 V @ 2.0 A (max.) / 60 - 90/ 100 -260 VAC ²			
Operating Temperature	-20 to +60°C			
Storage Temperature	-40 to +85°C			
Relative Humidity	Up to 95% (non-condensing)			
Physical Dimensions W x H x D in. (cm)	5.0" x 9.5" x 2.1" (12.7 x 24.1 x 5.3)			
Weight lbs. (kg)	3 (1.4)			

¹ 0 dBm optical input

² Using external power inserter

Return Path Receiver Specifications (P/N 5600)

RF and Optical Specifications	
Optical	
Input Optical Power Range	-4 to +1 dBm
Connector	SC/ APC (FC /APC optional)
RF	
Pass band	5 to 300 MHz
Impedance	75 Ohms
RF Output Level*	20 to 30 dBmV
Flatness	±1 dB (Across Pass Band)
Return Loss	13 dB
General Specifications	
7180M Chassis Capacity	8 plug-ins
Chassis Size	19" x 5.25" x 7"
Plug-in Unit Size	5.1" x 4.9" 1.6"
Power for Chassis	110 or 220 VAC 60 Watts (max.)
Operating Temperature Range	-20°C to +60°C
Storage Temperature	-20°C to 85°C

*@ -4 dBm Input @ 43 dB NPR @ 10 dB Link Gain

MiniNode Ordering Code

Model Number: 5801-(C)-(RPL)-(G)-(W)

Options:

C Optical Connectors:

SC SC/APC optical connector
FC FC/APC optical connector

RPL Return Path Laser

Fabry Perot
F1301 Fabry Perot 1 mW, 1310 nm
F1302 Fabry Perot 2 mW, 1310 nm unisolated
F1303 Fabry Perot 1 mW, 1310 nm

Standard DFB

D1552 DFB 2mW, 1550 nm
D1553 DFB 3mW, 1550 nm
D1554 DFB 4mW, 1550 nm

ITU DFB

11472 DFB 2mW, 1470nm
11492 DFB 2mW, 1490nm
11512 DFB 2mW, 1510nm
11532 DFB 2mW, 1530nm
11552 DFB 2mW, 1550nm
11572 DFB 2mW, 1570nm
11592 DFB 2mW, 1590nm
11612 DFB 2mW, 1610nm

G Gain Control

A Automatic Gain Control
M Manual Gain Control

W Internal WDM

W Internal 1310 + 1550 WDM

Foxcom Inc.

Princeton Forrestal Village
136 Main Street, Suite 300
USA
Tel: 609-514-1800
Toll Free: 1-866-ONEPATH
Fax: 609-514-1881

E-mail: sales@foxcom.com

Foxcom Ltd.

Beck Science Center
8 Hartom Street, Har-Hotzvim
P.O. Box 45092, Jerusalem 91450
Israel
Tel: +972-2-589-9888
Fax: +972-2-589-9898

Website: www.foxcom.com

Complete RF-2-Fiber Solutions